

**Cable Temperature Sensor**

Active sensor (0...10 V) for measuring the temperature in pipe and air applications. Incorporates a stainless steel probe and plenum-rated cable. NEMA 4X / IP65 rated enclosure.

**Type Overview**

Type	Output signal active temperature	Cable length	Probe length	Probe diameter
22CT-12H	DC 0...5 V, DC 0...10 V	2 m	50 mm	6 mm

**Technical Data**

<b>Electrical data</b>	Power supply DC	15...24 V, ±10%, 0.45 W		
	Power supply AC	24 V, , ±10%, 0.8 VA		
	Electrical connection	Removable spring loaded terminal block max. 2.5 mm <sup>2</sup>		
<b>Functional data</b>	Cable entry	Cable gland with strain relief Ø6...8 mm		
	Multirange	8 measuring ranges selectable		
	Output signal active note	Output DC 0...5/10 V with Jumper adjustable Voltage output: min. 5 kΩ load		
<b>Measuring data</b>	Application	Air Water		
	Measuring values	Temperature		
<b>Materials</b>	Measuring range temperature	Active sensor: range selectable Attention: max. measuring temperature is restricted by max. medium temperature (see Safety data)		
		Setting	range [°C]	range [°F] Factory setting
		S0	-50...50°C	-30...130°F
		S1	-10...120°C	0...250°F
		S2	0...50°C	40...140°F
		S3	0...250°C	30...480°F
		S4	-15...35°C	0...100°F
		S5	0...100°C	40...240°F
		S6	-20...80°C	40...90°F
		S7	0...160°C	0...150°F
	Accuracy temperature active	±0.5°C @ 21°C [±0.9°F @ 70°F]		
	Cable gland	PA6, black		
	Mounting plate	Lexan, grey RAL7001		
	Housing	Cover: Lexan, orange Bottom: Lexan, orange Seal: 0467 NBR70, black UV resistant		

<b>Safety data</b>	Ambient humidity	Max. 95% r.H., non-condensing
	Ambient temperature	-35...50°C [-30...120°F]
	Fluid temperature	-50...180°C [-60...355°F]
	Housing surface temperature	Max. 70°C [160°F]
	Protection class IEC/EN	III Protective extra-low voltage (PELV)
	Protection class UL	UL Class 2 Supply
	EU Conformity	CE Marking
	Certification IEC/EN	IEC/EN 60730-1
	Degree of protection IEC/EN	IP65
	Degree of protection NEMA/UL	NEMA 4X
	Quality Standard	ISO 9001

**Safety notes**

This device has been designed for use in stationary heating, ventilation and air-conditioning systems and must not be used outside the specified field of application. Unauthorised modifications are prohibited. The product must not be used in relation with any equipment that in case of a failure may threaten humans, animals or assets.

Ensure all power is disconnected before installing. Do not connect to live/operating equipment.

Only authorised specialists may carry out installation. All applicable legal or institutional installation regulations must be complied during installation.

The device contains electrical and electronic components and must not be disposed of as household refuse. All locally valid regulations and requirements must be observed.

**Remarks**
**General remarks concerning sensors**

When using lengthy connection wires (depending on the cross section used) the measuring result might be falsified due to a voltage drop at the common GND-wire (caused by the voltage current and the line resistance). In this case, 2 GND-wires must be wired to the sensor - one for supply voltage and one for the measuring current.

Sensing devices with a transducer should always be operated in the middle of the measuring range to avoid deviations at the measuring end points. The ambient temperature of transducer electronics should be kept constant. The transducers must be operated at a constant supply voltage ( $\pm 0.2$  V). When switching the supply voltage on/off, onsite power surges must be avoided.

**Build-up of Self-Heating by Electrical Dissipative Power**

Temperature sensors with electronic components always have a dissipative power which affects the temperature measurement of the ambient air. The dissipation in active temperature sensors shows a linear increase with rising operating voltage. The dissipative power should be taken into account when measuring temperature. In case of a fixed operating voltage ( $\pm 0.2$  V) this is normally done by adding or reducing a constant offset value. As Belimo transducers work with a variable operating voltage, only one operating voltage can be taken into consideration, for reasons of production engineering. Transducers 0...10 V / 4...20 mA have a standard setting at an operating voltage of DC 24 V. That means, that at this voltage, the expected measuring error of the output signal will be the least. For other operating voltages, the offset error will be increased by a changing power loss of the sensor electronics. If a re-calibration should become necessary later directly on the sensor, this can be done by means of a trimming potentiometer on the sensor board.

**Scope of delivery**

Scope of delivery	Description	Type
	Mounting plate S housing	A-22D-A09
	Dowel	
	Screws	

**Accessories**

<b>Optional accessories</b>	<b>Description</b>	<b>Type</b>
	Cold barrier, Plastic, L 50 mm, for thermowell pocket A-22P-A..	A-22P-A51
	Connection adapter, M20, for cable 1 x 6 mm, Multipack 10 pcs.	A-22G-A01.1
<b>Optional accessories air</b>	<b>Description</b>	<b>Type</b>
	Mounting flange for sensor probe 6 mm, up to max. 80°C, Plastic	A-22D-A03
	Mounting flange for sensor probe 6 mm, up to max. 260°C, Brass	A-22D-A05
<b>Recommended accessories water</b>	<b>Description</b>	<b>Type</b>
	Thermowell pocket (fabricated) Stainless steel, 50 mm, G1/2", SW27	A-22P-A06
	Thermowell pocket (fabricated) Stainless steel, 100 mm, G1/2", SW27	A-22P-A08
	Thermowell pocket (fabricated) Stainless steel, 150 mm, G1/2", SW27	A-22P-A10
	Thermowell pocket (fabricated) Stainless steel, 200 mm, G1/2", SW27	A-22P-A12
	Thermowell pocket (fabricated) Stainless steel, 300 mm, G1/2", SW27	A-22P-A14
	Thermowell pocket (fabricated) Stainless steel, 450 mm, G1/2", SW27	A-22P-A16
	Thermowell pocket (fabricated) Brass, 50 mm, R1/2", SW22	A-22P-A18
	Thermowell pocket (fabricated) Brass, 100 mm, R1/2", SW22	A-22P-A20
	Thermowell pocket (fabricated) Brass, 150 mm, R1/2", SW22	A-22P-A22
	Thermowell pocket (fabricated) Brass, 200 mm, R1/2", SW22	A-22P-A24
	Thermowell pocket (fabricated) Brass, 300 mm, R1/2", SW22	A-22P-A26
	Thermowell pocket (fabricated) Brass, 450 mm, R1/2", SW22	A-22P-A28
	Syringe with thermal paste	A-22P-A44
	Compression fitting, Stainless steel, G 1/4" (external thread) for 6 mm, with cutting ring	A-22P-A45

Wiring diagram

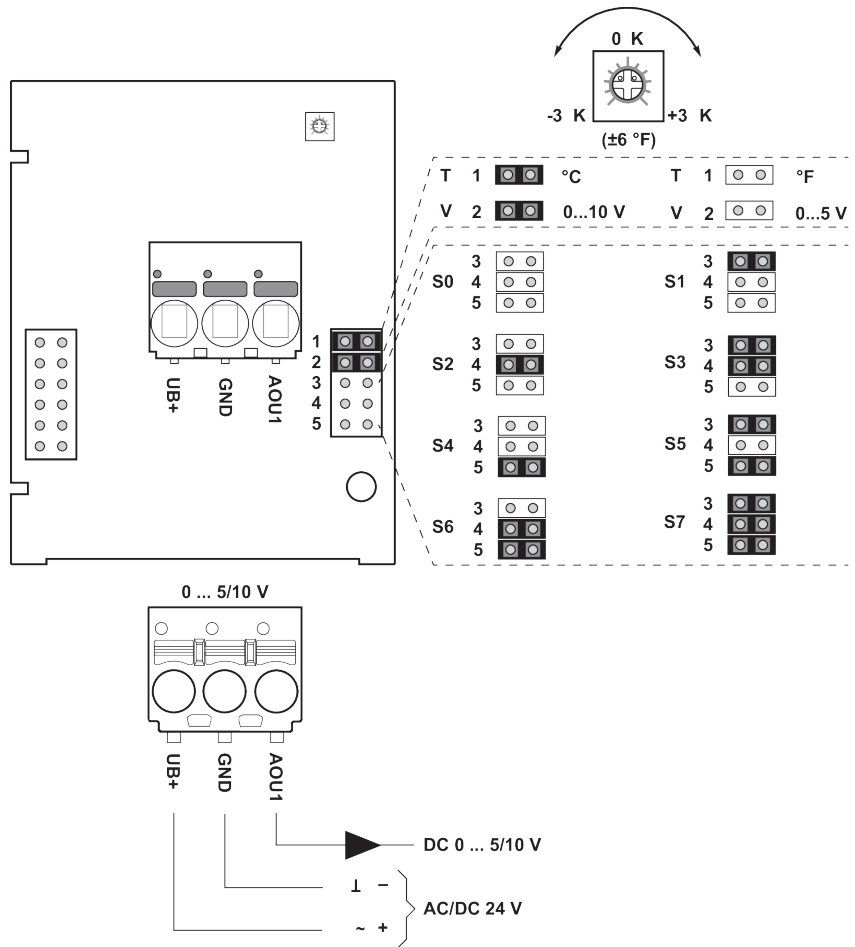

The adjustment of the measuring ranges is made by changing the bonding jumpers. The output value in the new measuring range is available after 2 seconds.

Setting	range [°C]	range [°F]	Factory setting
S0	-50...50°C	-30...130°F	
S1	-10...120°C	0...250°F	
S2	0...50°C	40...140°F	
S3	0...250°C	30...480°F	
S4	-15...35°C	0...100°F	
S5	0...100°C	40...240°F	
S6	-20...80°C	40...90°F	
S7	0...160°C	0...150°F	✓

Dimensions

Dimensions

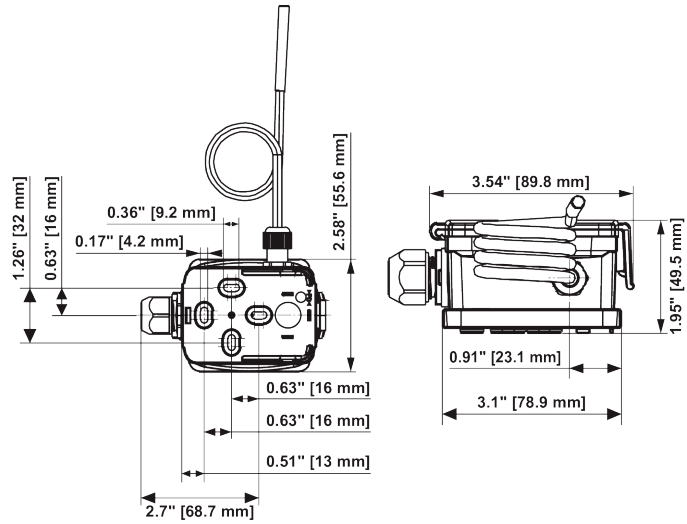

Type	Probe length	Weight
22CT-12H	50 mm	0.20 kg