

**Changeover ball valve, 3-way, External thread**

- For open and closed cold and warm water systems
- For switching functions and 2-point controls on the water side of air-handling units and heating systems
- Suitable for potable water
- Air bubble-tight (control path A - AB)

**Type overview**

Type	DN [ ]	DN ["]	G ["]	kvs [ m <sup>3</sup> /h]	PN [ ]
R515	15	1/2	1	8.6	40
R520	20	3/4	1 1/4	21	40
R525	25	1	1 1/2	26	40
R530	32	1 1/4	2	16	40
R532	32	1 1/4	2	32	25
R540	40	1 1/2	2 1/4	32	25
R550	50	2	2 3/4	49	25

**Technical data**

<b>Functional data</b>	Fluid	Cold and hot water, potable water, water with glycol up to max. 50% vol.
	Fluid temperature	-10...100°C
	Fluid temperature note	At a fluid temperature of -10...2°C, a valve neck extension is recommended. The allowed fluid temperature can be limited, depending on the type of actuator. Limitations can be found in the respective data sheets of the actuators.
	Permissible operating pressure ps	1600 kPa
	Close-off pressure Δps	1400 kPa
	Differential pressure Δpmax	400 kPa
	Differential pressure note	200 kPa for low-noise operation
	Flow	Bypass B – AB: Approx. 50% of kvs value
	Leakage rate	Port A – AB: air-bubble tight, leakage rate A (EN 12266-1); Bypass B – AB: Leakage class I (EN 1349 and EN 60534-4) max. 1% of the kvs value
	Angle of rotation	90°
	Pipe connectors	External thread according to ISO 228-1
	Installation position	upright to horizontal (in relation to the stem)
	Servicing	maintenance-free
	<b>Materials</b>	Housing
Closing element		Stainless steel
Stem		Stainless steel
Stem seal		EPDM O-ring
Ball seat		PTFE, O-ring Viton
Grease		Klübersynth VR 69-252N (potable water grade)

## Safety notes



- The valve has been designed for use in stationary heating, ventilation and air-conditioning systems and must not be used outside the specified field of application, especially in aircraft or in any other airborne means of transport.
- Only authorised specialists may carry out installation. All applicable legal or institutional installation regulations must be complied during installation.
- The valve does not contain any parts that can be replaced or repaired by the user.
- The valve may not be disposed of as household refuse. All locally valid regulations and requirements must be observed.
- When determining the flow rate characteristic of controlled devices, the recognised directives must be observed.

## Product features

**Mode of operation** The open/close ball valve is adjusted by a rotary actuator. The rotary actuator is connected by an open/close signal. Open the ball valve counterclockwise and close it clockwise.

## Accessories

	Description	Type
<b>Electrical accessories</b>	Stem heating DN 15...50 (20 W)	ZR24-2
	Description	Type
<b>Mechanical accessories</b>	Pipe connector for ball valve DN 15 Rp 1/2"	ZR4515
	Pipe connector for ball valve DN 20 Rp 3/4"	ZR4520
	Pipe connector for ball valve DN 25 Rp 1"	ZR4525
	Pipe connector for ball valve DN 32 Rp 1 1/4"	ZR4532
	Pipe connector for ball valve DN 40 Rp 1 1/2"	ZR4540
	Pipe connector for ball valve DN 50 Rp 2"	ZR4550
	Valve neck extension for ball valve DN15...50	ZR-EXT-01

## Installation notes

**Recommended installation positions** The ball valve can be installed upright to horizontal. The ball valve may not be installed in a hanging position, i.e. with the stem pointing downwards.

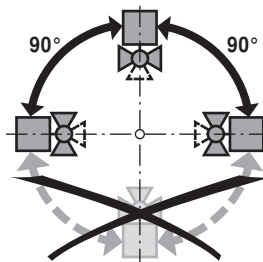

**Water quality requirements** The water quality requirements specified in VDI 2035 must be adhered to. Belimo valves are regulating devices. For the valves to function correctly in the long term, they must be kept free from particle debris (e.g. welding beads during installation work). The installation of a suitable strainer is recommended.

**Servicing** Ball valves and rotary actuators are maintenance-free. Before any service work on the final controlling device is carried out, it is essential to isolate the rotary actuator from the power supply (by unplugging the electrical cable if necessary). Any pumps in the part of the piping system concerned must also be switched off and the appropriate slide valves closed (allow all components to cool down first if necessary and always reduce the system pressure to ambient pressure level). The system must not be returned to service until the ball valve and the rotary actuator have been correctly reassembled in accordance with the instructions and the pipeline has been refilled by professionally trained personnel.

## Installation notes

**Flow direction** The direction of flow, specified by an arrow on the housing, is to be complied with, since otherwise the ball valve could become damaged. Please ensure that the ball is in the correct position (marking on the spindle).

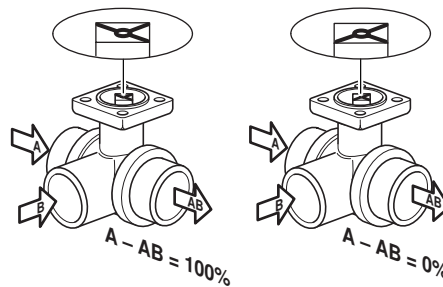

## Dimensions / Weight

### Dimensional drawings

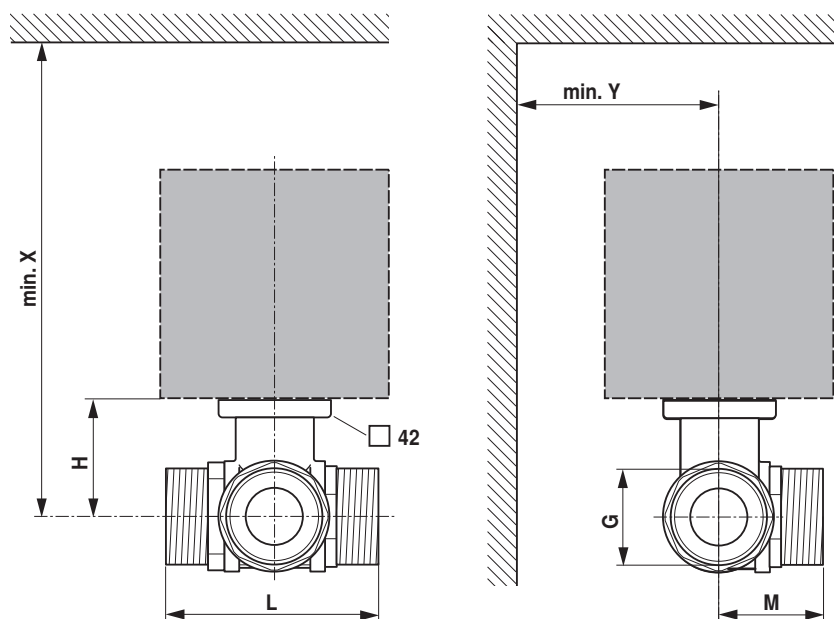

X/Y: Minimum distance with respect to the valve centre.  
The actuator dimensions can be found on the respective actuator data sheet.

Type	DN [ ]	G [“]	L [ mm]	M [ mm]	H [ mm]	X [ mm]	Y [ mm]	Weight
R515	15	1	74	39	44	220	90	0.61 kg
R520	20	1 1/4	85.5	41.5	46	220	90	0.94 kg
R525	25	1 1/2	84.5	45	46	220	90	1.1 kg
R530	32	2	103.5	55.5	46	220	90	1.7 kg
R532	32	2	107.5	55.5	50.5	230	90	1.8 kg
R540	40	2 1/4	114.5	56	50.5	230	90	2.1 kg
R550	50	2 3/4	131.5	68	56	240	90	3.7 kg

## Further documentation

- The complete product range for water applications
- Data sheets for actuators
- Installation instructions for actuators and/or ball valves
- General notes for project planning